



Integrating plastic technologies  
since 1965

# HYDRAULIC BOX DUMPER

## STANDARD FEATURES:

- Bucket rotation 135 degrees
- Motor 1.5 h.p.
- NEMA 12 electrical enclosure
- Hydraulic cylinders w/ 24" stroke, 2" bore, 2" rod
- Adjustable retaining bar 32" to 48"
- Up cycle complete, limit switch
- Down cycle flow control valve
- Cycle time 30 seconds up, 15 seconds down
- Greasable sleeve type main bearing

## OPTIONAL FEATURES:

- Gaylord entry guides
- Velocity fuse (catches bucket in case of hydraulic rupture)
- Custom size and shape buckets
- Dust hood with discharge hatch
- Dust containment doors on bucket
- Dumper stands 12" to 72"
- Floor grate in bucket
- Double acting hydraulics
- Explosion proof electrical
- Stainless steel chute liner
- Stainless steel construction
- Custom paints and matching colours

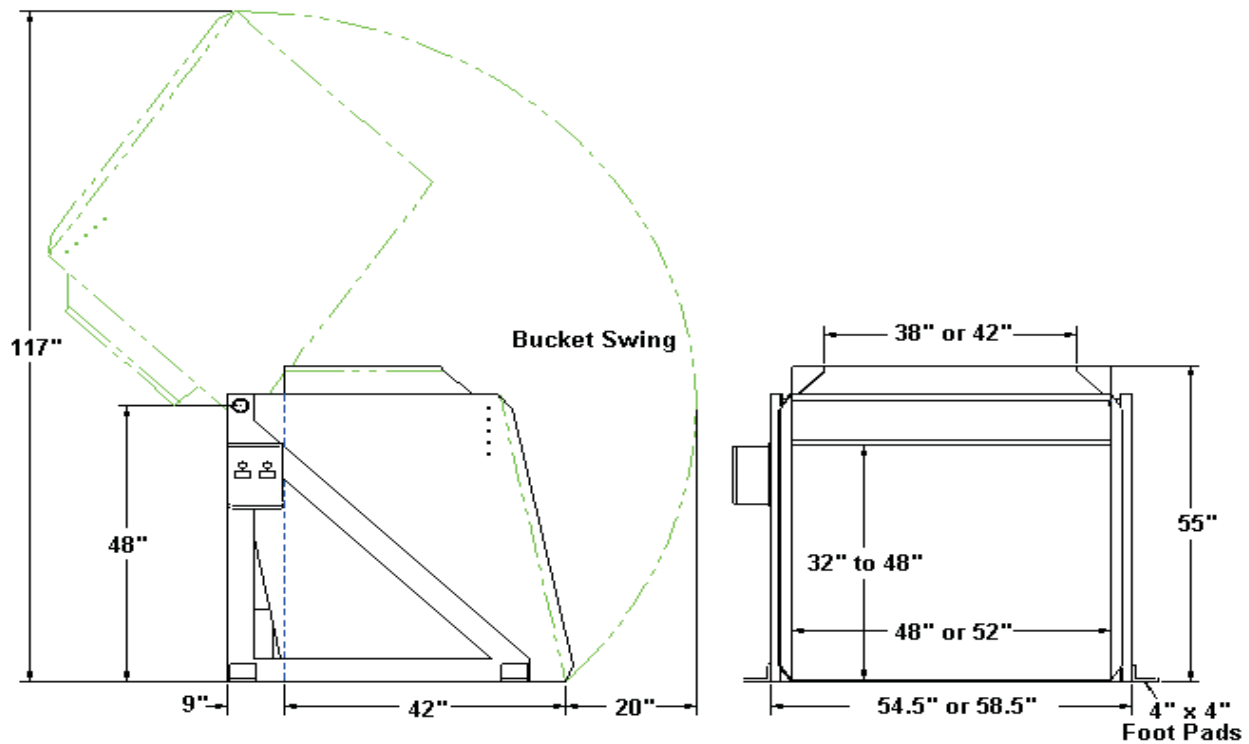

**Hamilton Plastic Systems Ltd.**  
230 Brunel Rd., Mississauga, ON L4Z 1T5  
905-890-0055 • 1-800-590-5546  
sales@HamiltonPSL.com  
www.hamiltonplasticsystems.com

**Representative:**



Integrating plastic technologies since 1965