

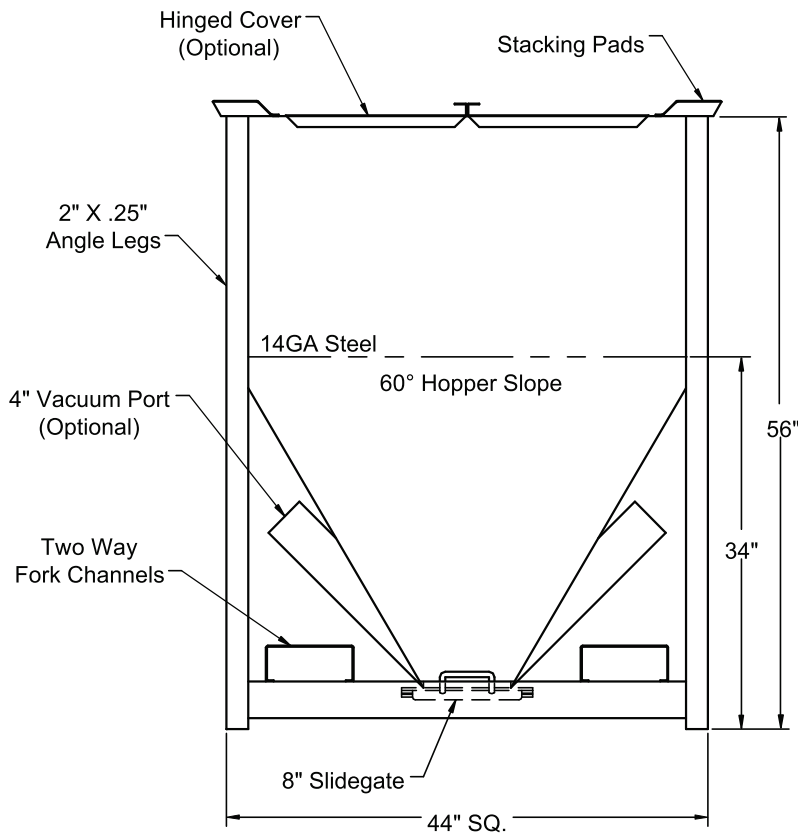

Integrating plastic technologies
since 1965

PORTABLE STORAGE BINS

60° Bin



STANDARD FEATURES:

- Two way fork channels
- Flared stacking pads
- 14 ga. Hopper
- 2" x 1/4" Angle legs
- 8" Slide gate
- 60 deg. Hopper slope
- Hamilton grey enamel exterior

OPTIONAL FEATURES:

- One or two way vacuum ports
- Hinged covers
- Pallet jack entries
- Four way fork channels
- Foot pads
- 4" Casters (2- rigid, 2- swivel)
- One piece lay-on cover
- 1/3 - 2/3 Cover with loader mounting
- Epoxy interior lining
- Stainless steel construction
- Custom sizes and capacities
- Custom paints and matching colors

SPECIFICATIONS:

Model No.	Capacity	Height
40-3300	30 cu.ft.	56"

Hamilton Plastic Systems Ltd.
230 Brunel Rd., Mississauga, ON L4Z 1T5
905-890-0055 • 1-800-590-5546
sales@HamiltonPSL.com
www.hamiltonplasticsystems.com

Representative:



Integrating plastic technologies since 1965