



Integrating plastic technologies
since 1965

DECLINED BELT CONVEYORS

SV series

The SV series conveyors feature reliable performance and ease of operation, and are suitable for conveying finished product fed from robots to a lower level.

The angle and height of conveyor is adjustable.

FEATURES:

- Non-slip PU belt
- Sidewalls with 34mm height
- Fixed speed of 6 metres/minute
- Adjustable angle from -25° to $+25^{\circ}$
- Mounted on height adjustable support legs
- Three phase motor with gearbox for voltages 230/400/460/575V, frequency 50/60Hz



Model SV-1



Gear motor and control unit

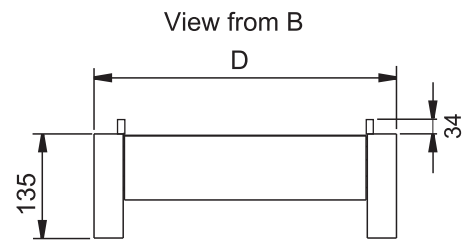
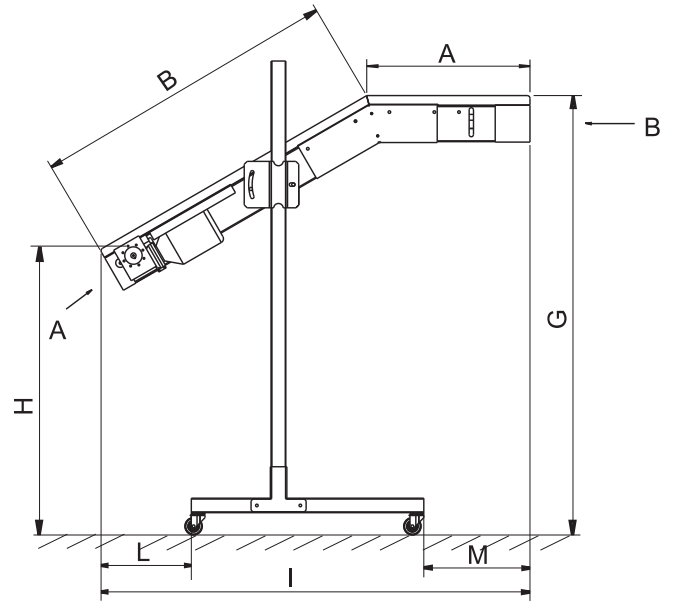
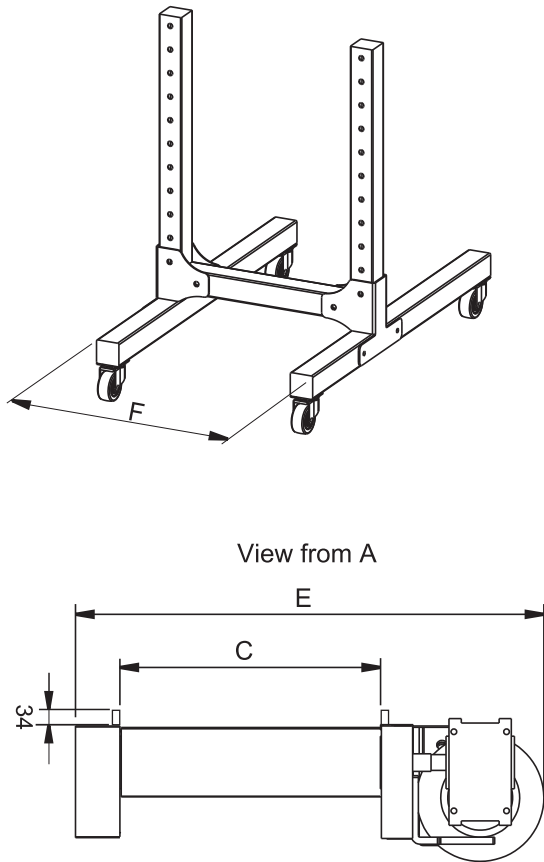

SPECIFICATIONS:

Model	SV-1	SV-2	SV-3	SV-4	SV-5	SV-6
A	533	533	533	1033	1033	1033
B	1033	1033	1033	1533	1533	1533
C	300	370	500	370	500	600
D	425	495	625	495	625	1533
E	527	597	727	597	727	600
F	490	560	690	560	690	1533
G	800~1600	800~1600	800~1600	1050~2400	1050~2400	1050~2400
H	320~1120	320~1120	320~1120	320~1670	320~1670	320~1670
I	1470	1470	1470	2400	2400	2400
L	284	284	284	620	620	620
M	379	379	379	670	500	670
Weight (kg)	83	88	93	110	120	130